



POWER GENERATION PRODUCT SELECTION GUIDE

Solar[®] Turbines
A Caterpillar Company

INDUSTRIAL GAS TURBINE PRODUCT LINE AND PERFORMANCE

INDUSTRIAL GAS TURBINE PRODUCT LINE

Saturn®	Centaur®	Taurus™	Mars®	Titan™
Saturn 20 1.2 MW 14 795 kJ/kWe-hr (14,025 Btu/kWe-hr)	Centaur 40 3.5 MW 12 910 kJ/kWe-hr (12,240 Btu/kWe-hr)	Taurus 60 5.7 MW 11 430 kJ/kWe-hr (10,830 Btu/kWe-hr)	Mars 100 11.4 MW 10 935 kJ/kWe-hr (10,365 Btu/kWe-hr)	Titan 130 15.0 MW 10 230 kJ/kWe-hr (9695 Btu/kWe-hr)
	Centaur 50 4.6 MW 12 270 kJ/kWe-hr (11,630 Btu/kWe-hr)	Taurus 65 6.3 MW 10 945 kJ/kWe-hr (10,375 Btu/kWe-hr)		Titan 250 21.7 MW 9260 kJ/kWe-hr (8775 Btu/kWe-hr)
		Taurus 70 8.0 MW 10 505 kJ/kWe-hr (9955 Btu/kWe-hr)		

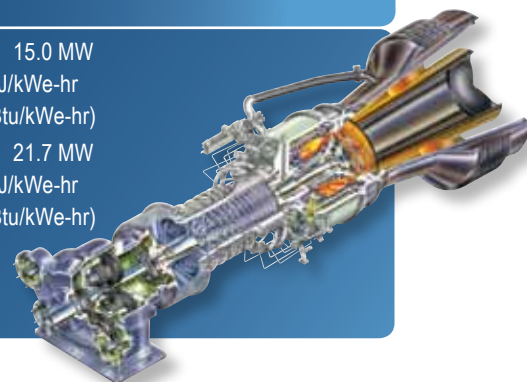

RECUPERATED GAS TURBINE

Mercury™

Mercury 50 4.6 MW
9350 kJ/kWe-hr
(8865 Btu/kWe-hr)

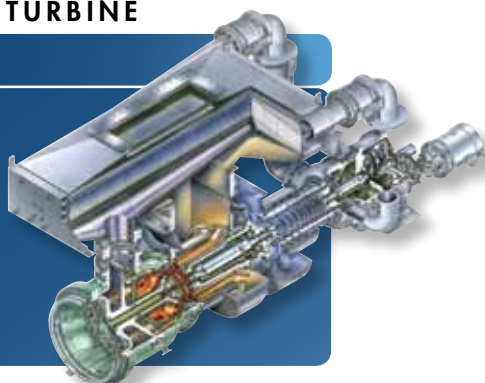

Mercury 50 Generator Set
Cogeneration and Distributed Energy
Austin, Texas

HEAT RECOVERY PERFORMANCE DATA

		Saturn 20	Centaur 40	Centaur 50	Mercury 50	Taurus 60	Taurus 65	Taurus 70	Mars 100	Titan 130	Titan 250	
ISO - No Losses	Exhaust Temperature, °C (°F)	505 (940)	445 (830)	510 (950)	365 (690)	510 (950)	550 (1020)	505 (945)	485 (905)	495 (925)	465 (865)	
	Exhaust Mass Flow, thousand kg/hr (thousand lbs/hr)	23.5 (51.9)	68.4 (150.7)	68.7 (151.4)	64.1 (141.4)	78.4 (172.8)	76.0 (167.4)	96.8 (213.4)	153.2 (337.9)	179.3 (395.2)	245.6 (541.4)	
	Turbine Fuel Input, GJ/hr (MMBtu/hr)	17.8 (16.9)	45.3 (43.0)	56.4 (53.5)	43.0 (40.8)	64.8 (61.4)	69.0 (65.4)	83.7 (79.3)	124.1 (117.6)	153.4 (145.4)	201.3 (190.8)	
Site Assumptions	Process Steam Production (Unfired)											
	Steam Output, tonnes/hr (thousand lbs/hr)	4.0 (8.7)	8.9 (19.6)	11.5 (25.3)	6.0 (13.1)	13.5 (29.8)	14.7 (32.4)	16.5 (36.4)	23.7 (52.3)	29.2 (64.5)	35.2 (77.6)	
	Process Steam Production with Supplemental Firing, 871°C (1600°F)											
	Steam Output, tonnes/hr (thousand lbs/hr)	8.4 (18.5)	24.1 (53.0)	23.9 (52.7)	22.3 (49.2)	28.1 (61.9)	27.2 (60.0)	34.4 (75.8)	54.1 (119.3)	63.9 (140.9)	87.4 (192.8)	
	Additional Fuel to Burner, GJ/hr (MMBtu/hr)	10.4 (9.9)	35.5 (33.6)	30.4 (28.8)	39.4 (37.3)	34.6 (32.8)	30.0 (28.4)	43.0 (40.8)	72.6 (68.8)	82.4 (78.1)	122.7 (116.3)	
	Process Steam Production with Maximum Supplemental Firing											
Steam Output, tonnes/hr (thousand lbs/hr)	17.7 (39.1)	50.9 (112.2)	50.4 (111.2)	47.1 (103.9)	58.9 (129.8)	57.1 (125.9)	72.3 (159.5)	113.8 (250.9)	134.1 (295.7)	135.1 (298.0)		
Additional Fuel to Burner, GJ/hr (MMBtu/hr)	32.7 (31.0)	100.1 (94.9)	95.6 (90.6)	100.4 (95.2)	109.1 (103.4)	102.2 (96.9)	135.3 (128.2)	218.4 (207.0)	253.3 (240.1)	235.0 (222.7)		

TYPICAL COMBINED HEAT AND POWER SYSTEM

ASSUMPTIONS:

Site Conditions		
Elevation	0 m	(0 ft)
Temperature	15°C	(59°F)
Fuel	Natural Gas	
Load	100%	
Inlet Pressure Loss, H ₂ O	100 mm	(4 in.)
Exhaust Pressure Loss, H ₂ O	254 mm	(10 in.)
Mercury 50	175 mm	(7 in.)

HRSG/Steam Data:

Steam Pressure	10.3 bar Gauge (150 psig)
Steam Conditions	Dry and Saturated
Boiler Inlet	110°C (230°F)

Notes:

- Alternative steam pressures and temperatures available upon request.
- Minimum stack temperature with gas fuel = 135°C (275°F), liquid fuel = 163°C (325°F).

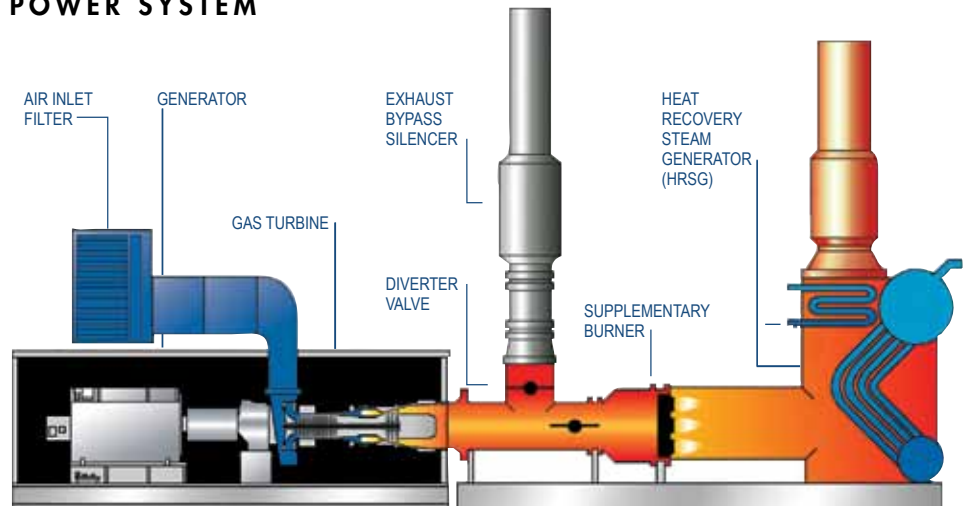

TYPICAL STEAM OUTPUT RANGES

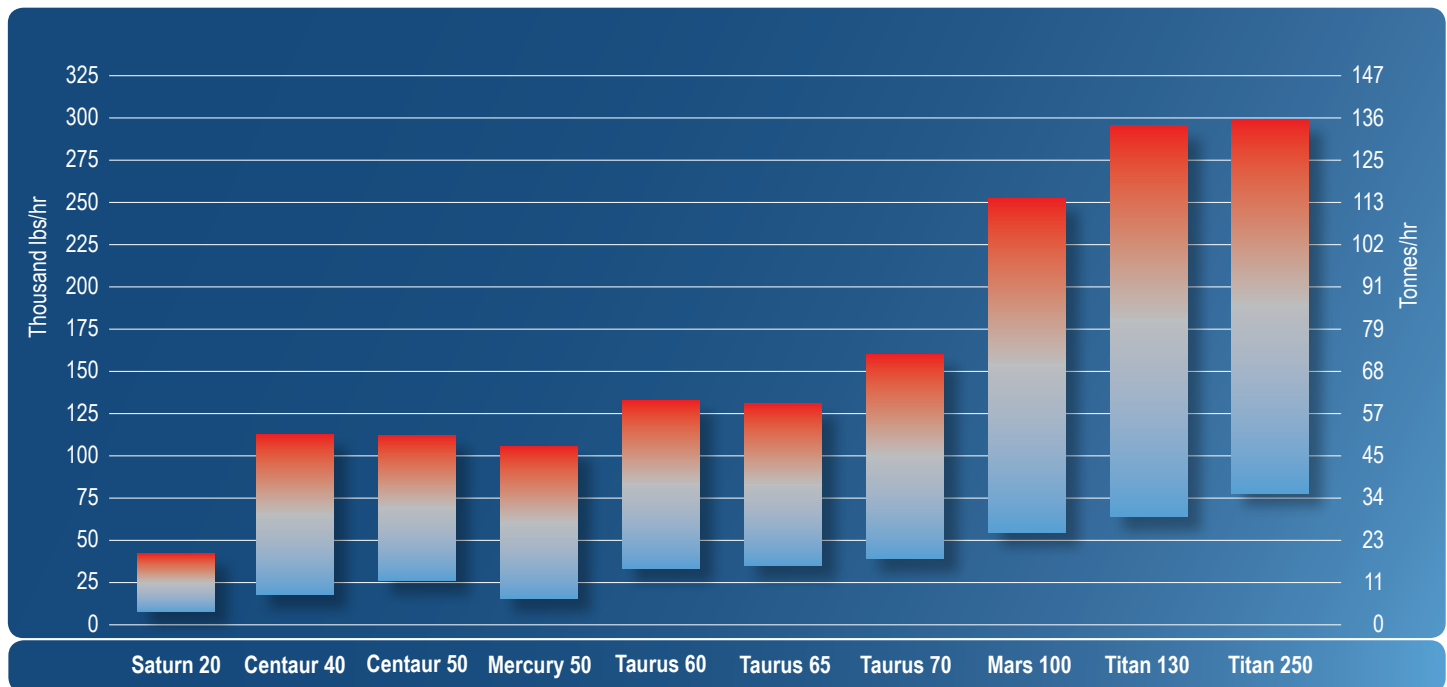

Note: Steam output ranges from an unfired basis (blue) to a max-fired rate (red).

CHILLED WATER PRODUCTION

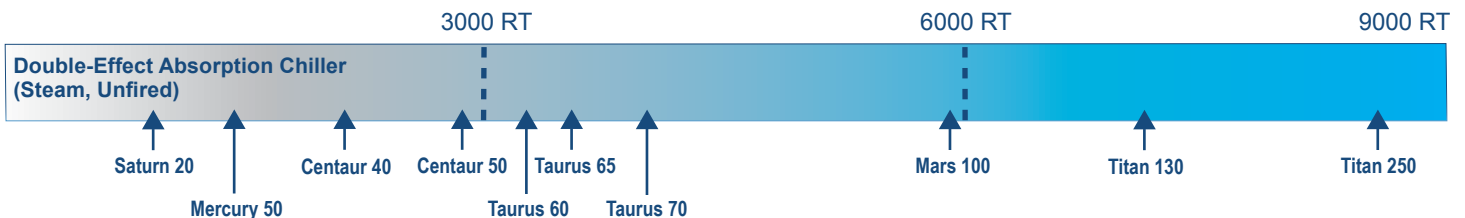

CONVERSION FACTORS FOR CHILLING APPLICATIONS:

Older Mechanical Chiller: 0.8 kW/hr = 1 Ton of Refrigeration, Newer Mechanical Chiller: 0.6 kW/hr = 1 Ton of Refrigeration
 Single-Effect Absorption Chiller: 18.7 lb/hr of Steam = 1 Ton of Refrigeration, Double-Effect Absorption Chiller: 9 lb/hr of Steam = 1 Ton of Refrigeration
 Alternative chiller configurations are also available including single effect, hot water and indirect-fired absorption.

APPROXIMATE PACKAGE DIMENSIONS AND WEIGHTS*

Generator Set Model	Length m (ft-in)	Width m (ft-in)	Height m (ft-in)	Dry Weight kg (lb)
Titan 250	18.4 (60' 3")	3.7 (12' 0")	4.1 (13' 5")	125 000 (276,000)
Titan 130	14.0 (46' 0")	3.2 (10' 7")	3.9 (12' 11")	86 900 (191,000)
Mars 100	14.2 (46' 6")	2.8 (9' 2")	3.8 (12' 6")	86 200 (190,000)
Taurus 70	10.8 (35' 7")	2.8 (9' 2")	3.7 (12' 2")	62 900 (139,000)
Taurus 65	9.8 (32' 2")	2.6 (8' 6")	3.3 (10' 9")	39 600 (87,300)
Taurus 60	9.8 (32' 2")	2.6 (8' 6")	3.2 (10' 5")	39 100 (86,100)
Mercury 50	11.2 (36' 6")	3.2 (10' 5")	3.7 (12' 3")	45 660 (100,700)
Centaur 50	9.8 (32' 2")	2.6 (8' 6")	3.2 (10' 5")	38 900 (85,800)
Centaur 40	9.8 (32' 2")	2.6 (8' 6")	3.2 (10' 5")	31 600 (69,600)
Saturn 20	6.7 (21' 11")	2.4 (8' 0")	2.7 (8' 11")	10 530 (23,215)

* Actual values vary with customer options specified, such as type of generator.

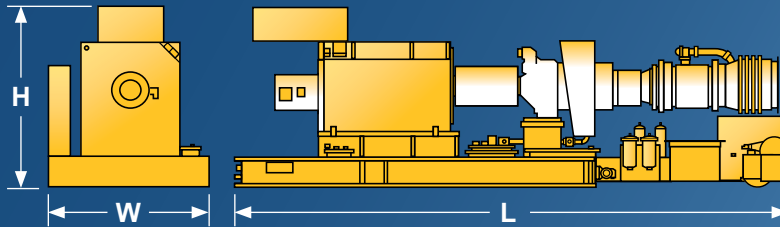

Solar Turbines offers a complete solution for your power needs. We can help with your requirements for combined heat and power, base-load electricity, dispersed power, combined cycle, peak shaving, district heating/cooling, distributed generation and standby power for a wide variety of facilities, including industrial/processing facilities, buildings and institutions, and distributed power plants.

Solar has been a pioneer in the design, manufacture and packaging of gas turbine systems for more than 50 years and is a world leader in the mid-range industrial gas turbine business.

Customers in more than 100 nations spanning the globe know they can rely on Solar Turbines to provide rugged, reliable Solar® turbomachinery systems. These systems are backed by Solar's Customer Services global network of 50 field offices around the world providing responsive field service, package overhaul and upgrades, technical training and genuine Solar certified service parts.

InSight System™, Solar's comprehensive online approach to equipment health management, includes the industry's most advanced remote monitoring and predictive diagnostics capabilities. Using InSight System, maintenance is based on equipment condition rather than time intervals. This saves time and money on repair and maintenance resulting in more uptime, greater productivity, and optimized life cycle.

For more information about how Solar can provide you with an effective solution to meet your energy needs, contact:

Solar Turbines Incorporated
P.O. Box 85376
San Diego, California 92186-5376
Telephone: +1 (619) 544-5352
email: powergen@solarturbines.com



www.solarturbines.com